

编译原理 · Quiz 2

1. An LR(1) parser can detect errors earlier than an LR(0) parser.

判断题 (4.0 分) (难度:中)

A. True

B. False

正确答案: A

答案解析: 暂无

2. If a grammar is LR(1), then the LALR(1) parsing table cannot have any reduce-reduce conflicts.

判断题 (4.0 分) (难度:中)

A. True

B. False

正确答案: B

答案解析: 暂无

3. The topological sort of attribute computation of is unique.

判断题 (4.0 分) (难度:中)

A. True

B. False

正确答案: B

答案解析: 暂无

4. An inherited attribute can be calculated by a postorder traversal of the parse tree.

判断题 (4.0 分) (难度:中)

A. True

B. False

正确答案: B

答案解析: 暂无

5. All inherited attributes can be changed into synthesized attributes by suitable modification of the grammar, without changing the language of the grammar.

判断题 (4.0 分) (难度:中)

A. True

B. False

正确答案: A

答案解析: 暂无

6. The input of semantic analysis phase is _____.

单选题 (4.0 分) (难度:中)

A. tokens

B. CFG

C. an abstract syntax tree

D. a parse tree

正确答案: C

答案解析: 暂无

7. Given the following declarations:

t1 = array [10] of int;

t2 = array [10] of int;

if t1 and t2 isequivalent, it follows _____ equivalence.

单选题 (4.0 分) (难度:中)

A. structural

B. name

C. declaration

D. none of the above

正确答案: A

答案解析: 暂无

8. When inheriting a previously computed synthesized attribute during LR parsing, it is suitable to treat the computed synthesized attribute as _____.

单选题 (4.0 分) (难度:中)

A. return value

B. passing as parameter

C. external data structure

D. just leaving it on the value stack

正确答案: C

答案解析: 暂无

9. A Yacc-generated parser employ _____ method to parse the input token stream.

单选题 (4.0 分) (难度:中)

A. top-down

B. LL(1)

C. SLR(1)

D. LALR(1)

正确答案: D

答案解析: 暂无

10. The symbol tables will not carry the _____ information about the variables.

单选题 (4.0 分) (难度:中)

A. data type

B. scope

C. liveness

D. location in memory

正确答案: A

答案解析: 暂无

11. Consider the CFG of number with a one-character suffix **o**(for octal) or **d** (for decimal).

based-num → num basechar

basechar → o | d

num → num digit | digit

digit → 0|1|2|3|4|5|6|7|8|9

In this case, we need two attributes, **base** (for indicating octal or decimal) and **val** (for value of the number).

(1) Rewrite the grammar so that the computation of the attribute base does not depend on parent nodes.

(2) Given the number "789o", show the dependency of attribute computation on its parsing tree of the above modified CFG.

简答题 (25.0 分) (难易度:中)

答案解析:

(1) The grammar can be modified as follows.

based-num → digit based-num | basechar

basechar → o | d

digit → 0|1|2|3|4|5|6|7|8|9

(2)

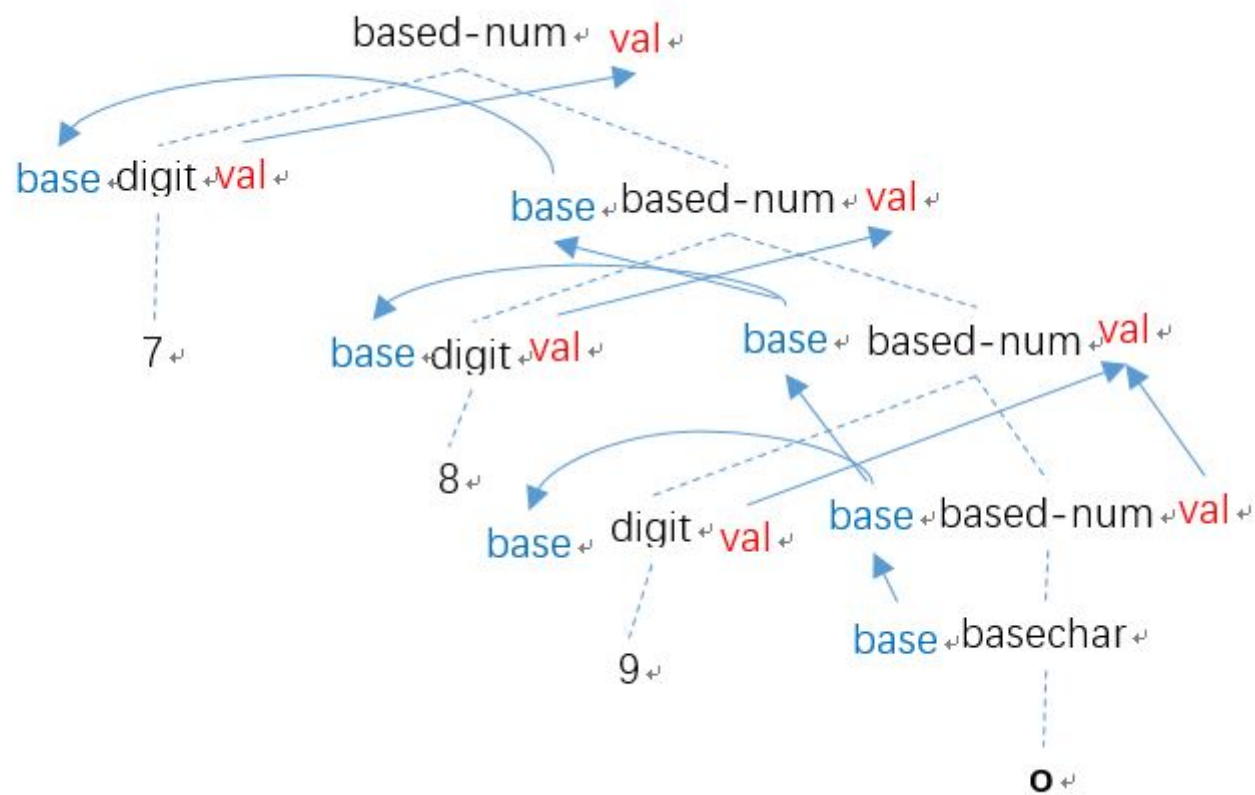

12. Consider an the following c-like code example.

```

1 double i;
2
3 void main()
4 {
5   int a, b, c;
6   {
7     int j = a+b;
8     int c = a*a+b*b;
9     char* a = "hello" ;
10    print(a); print(j); print(c);
11  }
12  print(b);
13 }

```

Suppose hash(i)=3, hash(a)=5, hash(b)=3, hash(c)=8, hash(j)=8, hash(f)=1, and only one symbol table is used.

(1) Show the symbol table when line 9 is executed first time.

(2) Show the symbol table when line 12 is executed.

简答题 (20.0 分) (难易度:中)

答案解析:

(1)

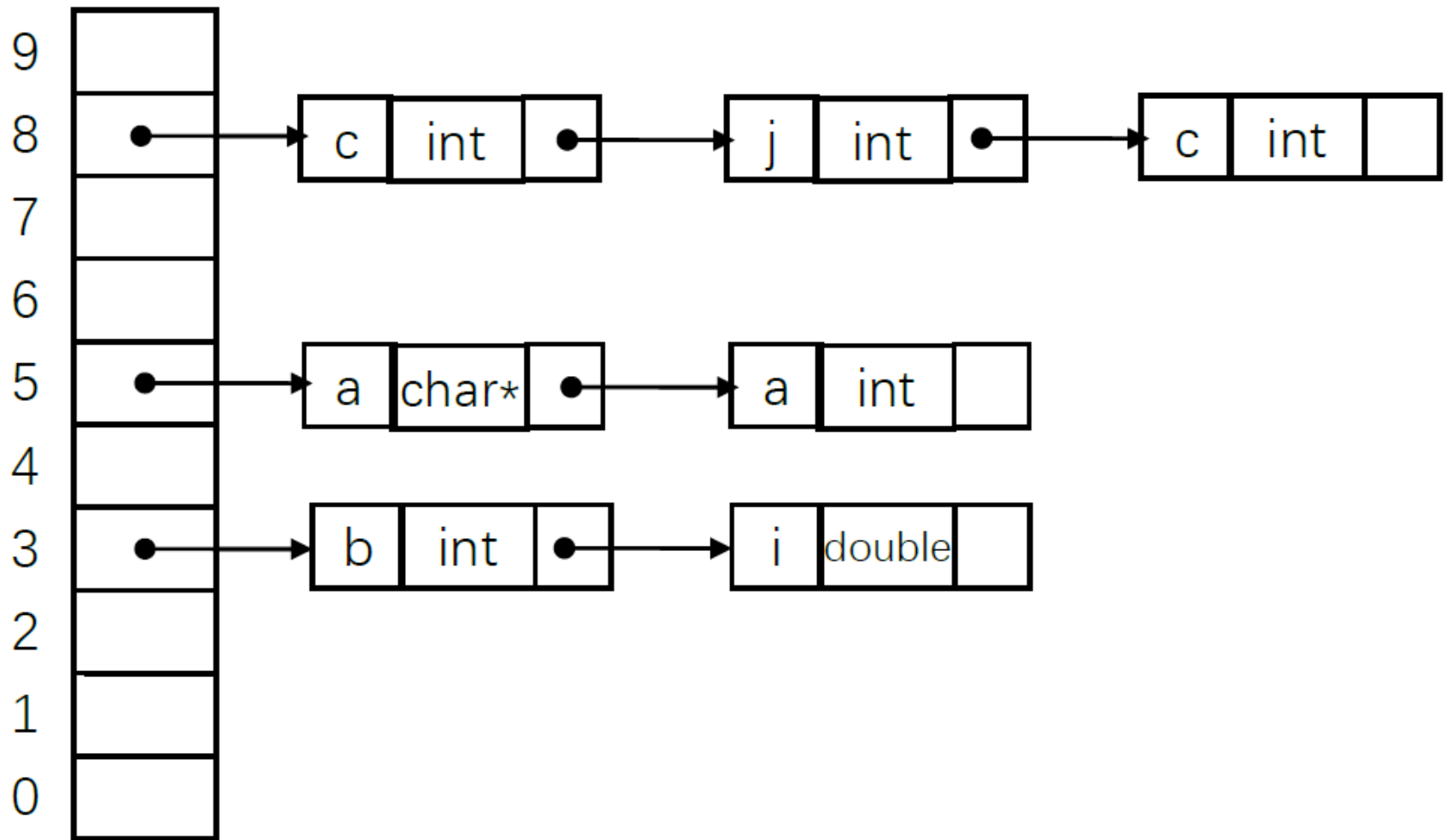

(2)

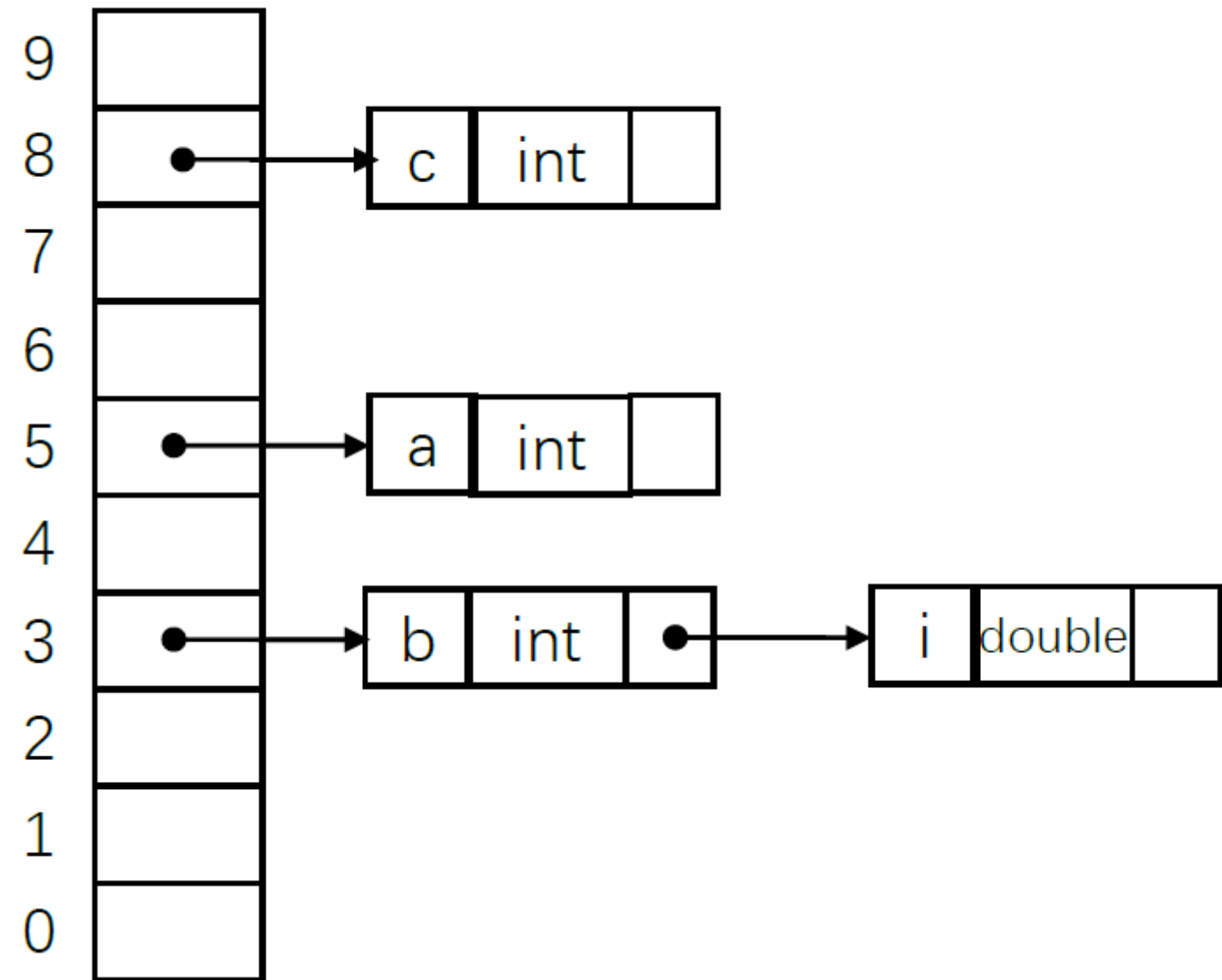

13. 2. Given the following grammar rules. (15 cents)

$S \rightarrow id \mid V := E$

$V \rightarrow id$

$E \rightarrow V \mid n$

Is this CFG LR(0), SLR(1), LR(1) and LALR(1)? Why?

简答题 (15.0 分) (难易度:中)

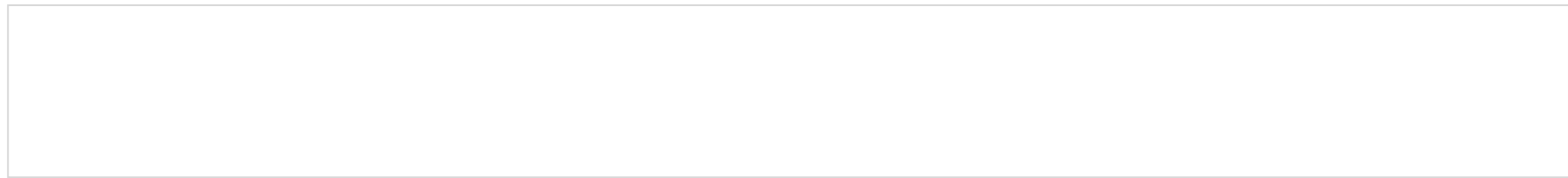

答案解析:

- (1) The above CFG is not LR(0), SLR(1), But it is LR(1) and LALR(1). (6 cents)
- (2) Because there are reduce-reduce conflicts in its LR(0) DFA and SLR(1) DFA, but there is no conflict in its LR(1) DFA and LALR(1) DFA. (9 cents)

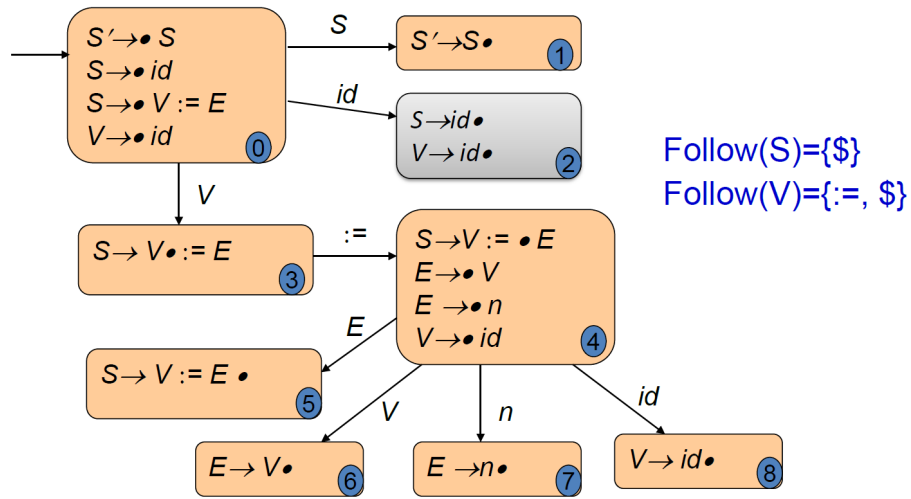

LR(0) DFA and SLR(1) DFA. There is reduce-reduce conflict in the state 2.

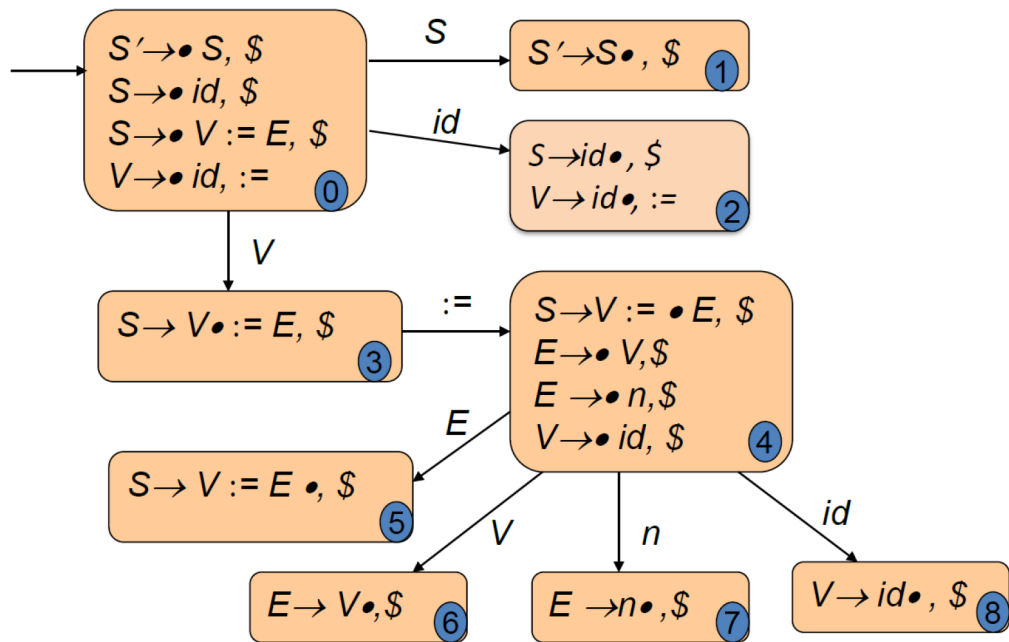

LR(1) DFA and LALR(1) DFA. The conflict in state 2 is resolved.

